



TiN Coated
HSS Step Drills
Two Spiral Flutes
with De-Burring Groove

Bordo's range of step drills are ideal for electrical contractors, sheetmetal workers and auto mechanics. Step drills are designed for drilling repetitive holes in steel, stainless steel, copper, brass, aluminium, plastic, plexiglas, laminates and many other thin materials. Manufactured from premium quality high speed steel with double fluted ground cutting edge for long service life.

The new range of Spiral Flute Titanium Nitride (TiN) coated step drills offer a range of additional benefits over the standard range of two flute bright finish drills.

- New high performance point for faster starting and reduced bit wander.
- 3 flatted shank prevents slipping in drill chuck.
- Spiral flutes enable easier tool penetration.
- TiN coating extends tool life, helps to dissipate heat, reduces friction and cold welding.
- Deburring groove simplifies deburring operation and negates the need for an additional manufacturing process.

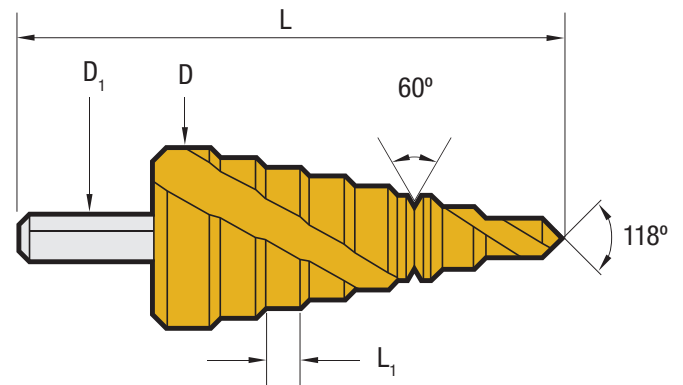

Spiral Flute TiN Step Drills

D mm	Capacity	L mm	L1 mm	D1 mm	Part Number
12.00	4-12 in 1 mm steps	79	5	6	2602-M1
20.00	4-20 in 2 mm steps	67	3	8	2602-M2
30.00	4-30 in 2 mm steps	100	4	10	2602-M3



Step Drill Merchandiser, 8 Piece – 2602-D2

Qty	Diameter mm / inch	Finish	Part Number
1	4-12	Bright	2600-M1
1	4-20	Bright	2600-M2
1	6-30	Bright	2600-M3
1	1/8-1/2	Bright	2600-1
1	1/4-3/4	Bright	2600-2
1	4-12	TiN SF	2602-M1
1	4-20	TiN SF	2602-M2
1	4-30	TiN SF	2602-M3



Step Drill, TiN Spiral Flute Set – 2602-S1

Qty	Diameter mm	Part Number
1	12.00	2602-M1
1	20.00	2602-M2
1	30.00	2602-M3



Contact Bordo International for further information

ABN 96 005 125 833

3 Kingston Park Court, PO Box 9199, Scoresby, Victoria 3179 Australia

T +61 3 9212 7000 F +61 3 9212 7070 E info@bordo.com.au W www.bordo.com.au

**drills
step**

single, set &
merchandise

HSS-TiN

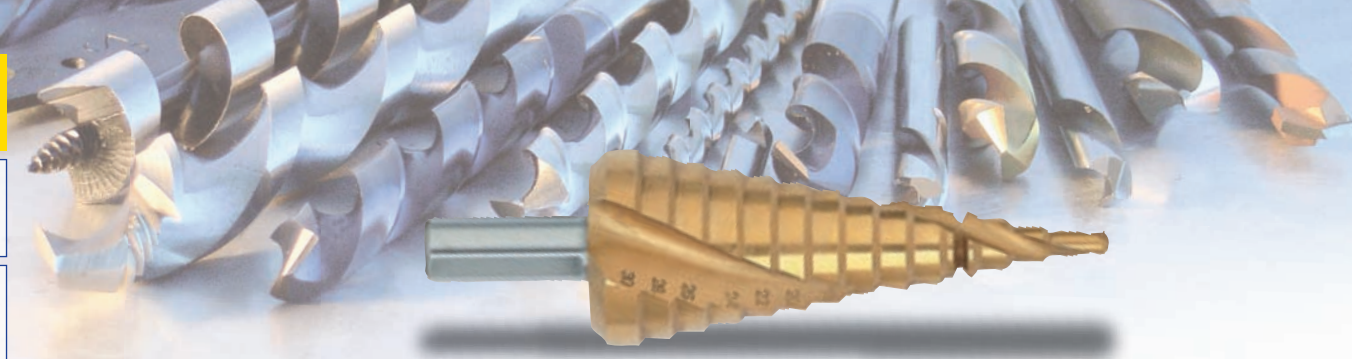

group	STEP
surface finish	gold coloured
material	HSS-TiN coated
flute type	sprial
flutes number	2
packaging	clam shell

DIAMETER		INCREMENT	STEP DEPTH	SHANK DIA.	OAL	PACK	\$	Part
min	max	mm	mm	mm	mm	qty	each	number
4	- 12	1.0	5.0	6.0	79.0	1	77.45	2602-M1
4	- 20	2.0	3.0	8.0	90.0	1	103.50	2602-M2
4	- 30	2.0	4.0	10.0	115.0	1	175.75	2602-M3



SET CONTENTS	PIECES	\$	Part
	qty	each	number
Metric Step Drill Set - Metal Case			
2602-M1, 2602-M2, 2602-M3	3	356.70	2602-S1



MERCHANDISER TYPE	\$	Part
	merchandise	number
Step Drills - Wall Mount	850.97	2602-D2

MERCHANDISER CONTENTS	Qty	Size	Part
	each	mm/inch	number
	1	4-12	2600-M1
	1	4-20	2600-M2
	1	6-30	2600-M3
	1	1/8-1/2	2600-1
	1	1/4-3/4	2600-2
	1	4-12	2602-M1
	1	4-20	2602-M2
	1	4-30	2602-M3